

HUNTRON[®] TRACKER[®]

MAINTENANCE MANUAL

FOR MODELS

HTR 1005B-1S

HTR 1005B-1ES

HTR 1005B-1JS

HUNTRON[®]

TABLE OF CONTENTS

XTEK

SPECIFICATIONS	2
GENERAL DESCRIPTION	3
THEORY OF OPERATION	5
The Test Signal	5
Testing Reactive Components	8
CIRCUIT DESCRIPTION	
Signal Section	10
Oscillator	12
Power Supply	12
Cathode Ray Tube Circuit	12
INTERNAL SET UP AND ADJUSTMENTS	17
TROUBLE SHOOTING	
General Information	19
Power Supply	19
Signal Section	22
CRT Section	24
Oscillator Section	24
LIST OF REPLACEMENT PARTS	25

© COPYRIGHT 1983 — HUNTRON® INSTRUMENTS, INC.

HTR 1005B-1S, B-1ES, B-1JS

The information contained herein is the exclusive property of Huntron® Instruments, Inc. (except as otherwise indicated) and shall not be reproduced in whole or in part without written authorization from the company.

All information contained in this manual is the latest product information available at the time of printing. Huntron® Instruments, Inc. reserves the right to make changes at any time without notice.

INTERCONNECTION ASSEMBLY:

(Refer to Figure 26)

REF. DES.	DESCRIPTION	HUNTRON® PART NO.	
MP1 (2)	Spacer, 1 Inch	07-7157	
MP2	Washer, Lock Star #6	07-7171	
MP3 (2)	Spacer, 1/4 Inch	07-7163	
MP4 (2)	Screw, Yoke	01-1017	
MP5	Screw, 3/8 Inch, 6/32	07-7172	
TR2	Transformer, Power	100 VAC 117 VAC 220/240 VAC	06-6033 06-6031 06-6032
	CRT Harness		07-1035

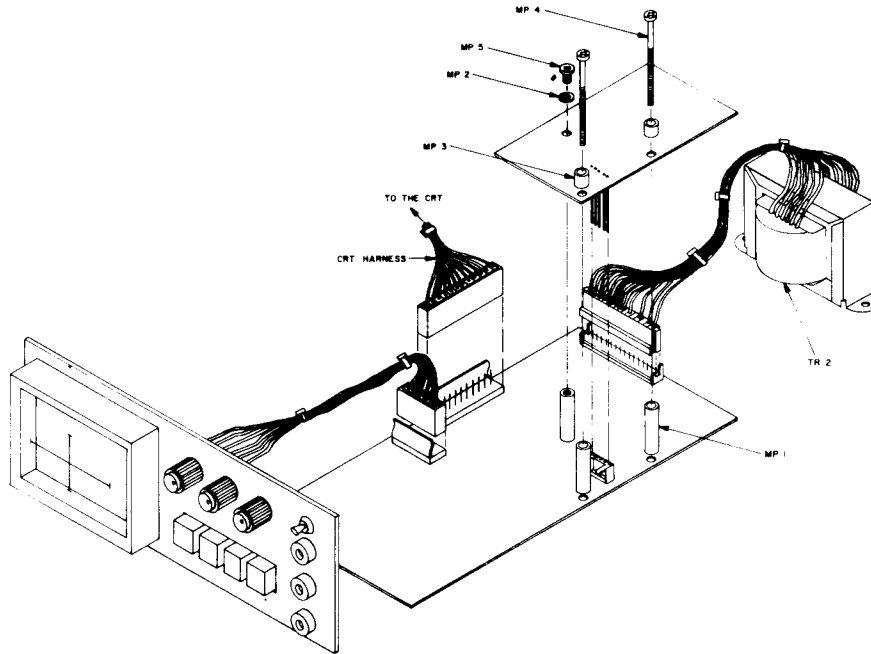

FIG.26

HUNTRON TRACKER® SPECIFICATIONS

POWER REQUIREMENTS:

HTR 1005B-1S	117VAC	60Hz
HTR 1005B-1ES	220/240VAC	50/60Hz
HTR 1005B-1JS	100VAC	50/60Hz

10 Watts Maximum

SIZE:

Width	8¾ Inch
Height	3½ Inch
Length	11½ Inch

WEIGHT 5 pounds 5 oz.

AMBIENT TEMPERATURE:

Operating	0 to 50 deg C
Storage	-50 to 60 deg C

SHOCK AND VIBRATION:

Will withstand shock and vibration encountered in commercial shipping and handling.

TEST SIGNAL DATA:

All ratings, except P-P voltages, are conditions existing across a single silicon diode in the test terminals of the **TRACKER®**.

Waveform	sine
Frequency	80 Hz

RANGE	OPEN-CIRCUIT P-P VOLTAGE VOLT	SHORT-CIRCUIT CURRENT mA R.M.S.	POWER mW R.M.S.	POWER mW PEAK	SHORT-CIRCUIT CURRENT mA PEAK
HIGH	120	0.29	0.26	0.52	0.8
MED.	40	0.27	0.23	0.45	0.7
LOW	20	64	81	161	170

CRT SCREEN SIZE	7 cm diagonal
ACCELERATION POTENTIAL	1350V. regulated

TRACE COMPARISON MODE:

ALTERNATE MODE alternates display between two inputs at 0.8 Hz for Good/Bad comparison.

PROTECTION CIRCUIT:

The **HUNTRON TRACKER®** provides protection against damage caused by touching probes with line circuits.

WARNING . . . THE SYSTEM TO BE CHECKED MUST HAVE POWER TURNED OFF, AND HAVE HIGH VOLTAGE CAPACITORS DISCHARGED.

CASE ASSEMBLY:

(Refer to **Figure 25**)

REF. DES.	DESCRIPTION	HUNTRON® PART NO.
CRT 1	Cathode Ray Tube	07-7059
MP1	Rear Extension Assembly B-1S, BIJS Models	01-2127
MP1	Rear Extension Assembly B1-ES Models	01-2128
MP2	Case, Top Assembly	01-2117
MP3 (2)	Screw, Yoke	01-1017
MP4 (2)	Spacer, Yoke	01-1116
MP5 (2)	Yoke Half	01-1114
MP6	Face Plate	01-1068
MP7	Handle Assembly	01-2119
MP8	Case, Bottom Assembly	01-2129
MP9 (4)	Case, Feet	01-1020
MP10 (4)	Screw, Case	01-1019
MP11	Shield, CRT	07-1000
MP12	Shield, Half	07-1011

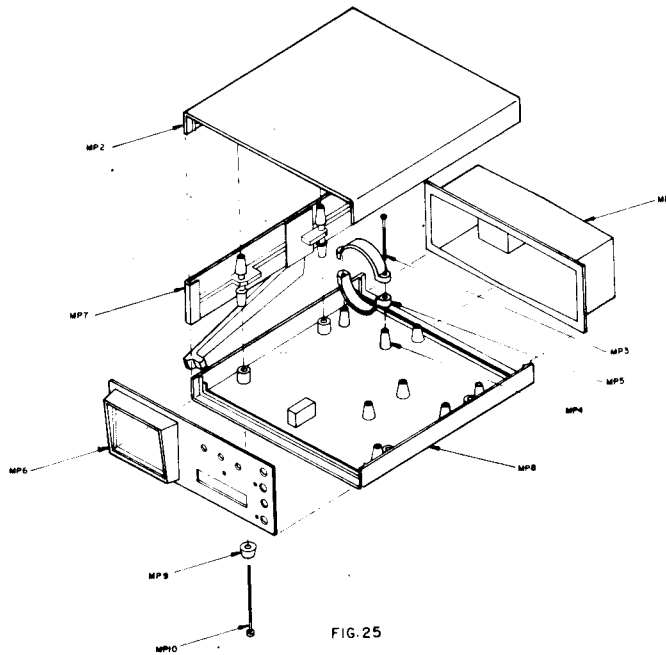

FIG. 25

GENERAL DESCRIPTION

The **HUNTRON TRACKER®** is a special type of CRT display and signal processing instrument that can be used to determine the quality of certain types of electronic components.

Components are tested with a two terminal system of test leads that are placed across the component under test. The test leads are inserted into the **TRACKER®** front panel. The **TRACKER®** is used to test components in a power-off condition, and can be used to test components mounted on printed circuit boards or other in-circuit conditions even with components bridged by various types of resistive values.

Devices that are normally tested by the **TRACKER®** include the following: semiconductor diodes, bipolar transistors, and field effect transistors; bipolar and MOS integrated circuits, including both analog and digital; certain types of capacitors and inductors.

Included as standard equipment with each **TRACKER®** is a set of **HUNTRON® MICRO PROBES™**. The **MICRO PROBE™** leads plug into the front panel test jacks. **MICRO PROBES™** have special tips so that they can be used to contact very small component terminals and small PCB etchings without the danger of shorting adjacent terminals and leads. Also included as standard equipment is a common test lead which is used with the **TRACKER®** in the "Compare-trace" mode (see **Figure 2**).

FRONT PANEL CONTROLS AND INDICATORS (Refer to **Figure 1**)

DISPLAY CONTROLS:

BRIGHT..... Controls the intensity of CRT display
VERT..... Controls the vertical position of CRT display
HORIZ..... Controls the horizontal position of CRT display

RANGE SELECTOR SWITCH:

Three interlocking pushbutton switches select one of three ranges characterized below.

HIGH..... Selects 120 V P-P sine wave test signal
MED..... Selects 40 V P-P sine wave test signal
LOW..... Selects 20 V P-P sine wave test signal

CHANNEL SELECT SWITCH:

Three position switch that selects the channel displayed.

Top position selects CHANNEL A.

Center position selects ALTERNATE MODE.

Bottom position selects CHANNEL B.

(ALTERNATE MODE alternates display between two inputs at 0.8 Hz for Good/Bad comparison.)

ON/OFF SWITCH..... 2-position pushbutton that turns the **TRACKER®** ON or OFF
CHANNEL A LED..... Indicates CHANNEL A input is being displayed
CHANNEL B LED..... Indicates CHANNEL B input is being displayed
ON/OFF INDICATOR LED..... Indicates POWER is ON or OFF
RED TERMINAL..... CHANNEL A INPUT
YELLOW TERMINAL..... CHANNEL B INPUT
BLACK TERMINAL..... INSTRUMENT COMMON

FRONT PANEL ASSEMBLY:

(Refer to Figure 24)

REF. DES.	DESCRIPTION	HUNTRON® PART NO.
A3	Control PCB Assembly	07-1034
D3	Diode, LED, Green XC209G	04-4009
J1	Banana Jack, Red	01-1030
J2	Banana Jack, Black	01-1031
J3	Banana Jack, Yellow	01-1032
K1	Knob	01-1060
K2	Knob	01-1060
K3	Knob	01-1060
MP1	Shaft, 5.9 Inch	07-7154
MP2	Coupler	07-7147
MP3	Spacer, Control Board	01-1035
MP4	Screw, Control Board	01-1036
MP5	Graticule	01-2002
MP6	Glass Lens	01-1006
MP7	Lens Gasket, Vertical	01-1066
MP8	Lens Gasket, Horizontal	01-1067
SW6	Switch, Toggle, SPDT (on-off-on)	07-7071

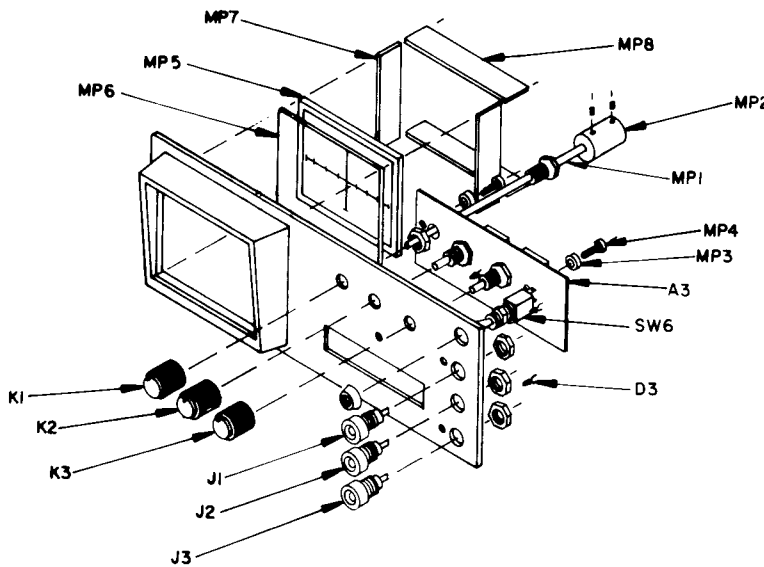
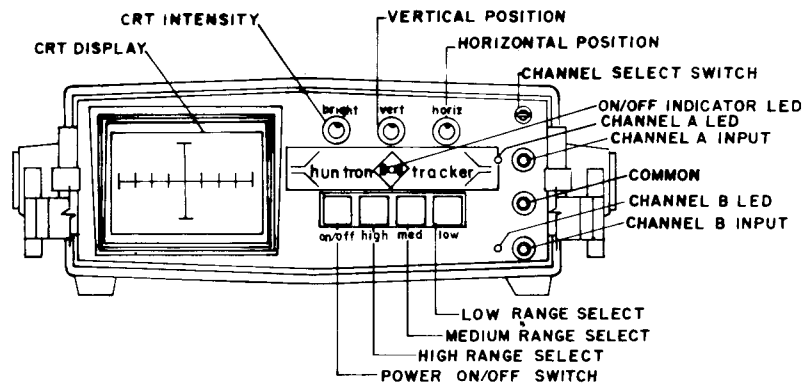

FIG. 24



LOCATIONS OF FRONT PANEL CONTROLS

FIG. 1

The **HUNTRON TRACKER®** can alternate automatically between the displays of CHANNEL A and CHANNEL B inputs. This allows the user to directly compare the display of the suspect circuit to that of a known good circuit for QA or troubleshooting. **Figure 2** shows how a **TRACKER®** can be used to compare a known good board with a board under test.

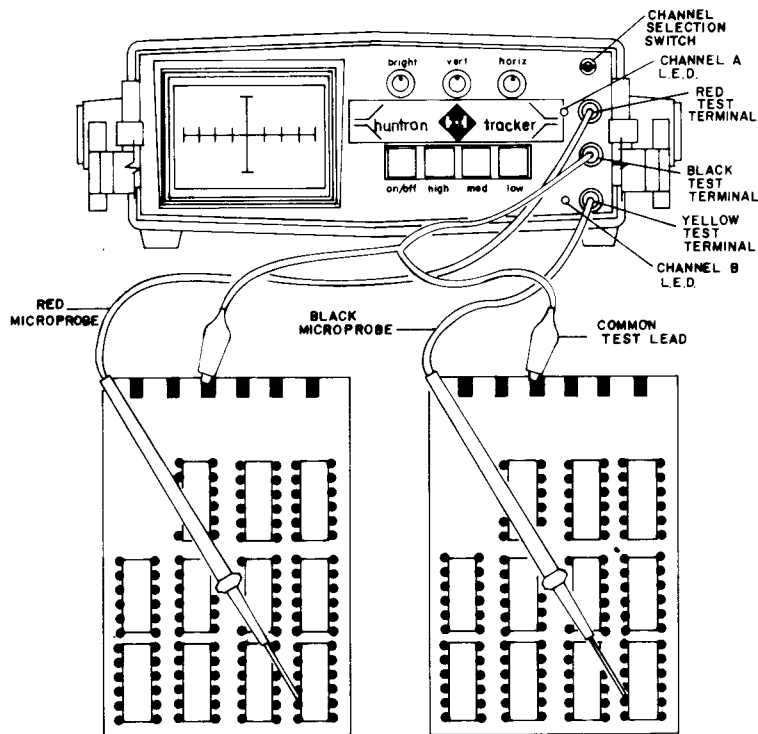

COMPARING A KNOWN GOOD BOARD WITH A BOARD UNDER TEST

FIG. 2

FRONT PANEL CONTROL PCB ASSEMBLY:

(Refer to **Figure 18** and **Figure 19**)

Unless otherwise specified:

All fixed resistors are ¼W, 5%, carbon film

All resistor values are in ohms

REF. DES.	DESCRIPTION		HUNTRON® PART NO.
A3	Control PCB Assembly		07-1034
PCB3	Control PCB		07-7707
C1	Cap, Mylar	0.1uF, 250V	03-3036
C2	Cap, Electrolytic	47uF, 6.3V	03-3041
C3	Cap, Electrolytic	47uF, 6.3V	03-3041
D1	Diode, LED, Green	XC209G	04-4009
D2	Diode, LED, Red	XC209R	04-4000
D3	Diode Signal	1N914	04-4007
D4	Diode, Signal	1N914	04-4007
IC1	IC, Timer	NE555	05-5006
MP1	Bushing		01-1059
R1	Pot, Control	1K	02-2149
R2	Pot, Control	1k	02-2149
R3	Res	15k	02-2151
R4	Res	470	02-2098
R5	Res	470	02-2098
R6	Res	10k	02-2137
R7	Res	10M	02-2152
R8	Res	470	02-2098
R9	Resistor	1.8k	02-2128
R10	Resistor	1.8k	02-2128
RY1	Relay, SPDT	835C-3 (Gordos)	07-7901
SO1	Socket, 6 Pin		07-7225

THEORY OF OPERATION

The **HUNTRON TRACKER**[®] applies a test signal across two terminals of the device being tested. This test signal causes a current to flow through the device and a voltage drop across its terminals.

The current flow is processed in such a way as to cause a vertical deflection of the scope trace, while the voltage across the test component causes a horizontal deflection of the scope trace.

THE TEST SIGNAL

This signal is an 80 Hz sine wave that alternately applies positive and negative voltages across the component being tested.

In an open circuit condition the positive half cycle generates the left side trace on the CRT, and the right side trace comes from negative half cycle. The 80 Hz test signal is generated on the Oscillator Board and presented at the front panel test terminals through a signal transformer. The transformer has the dual purpose of adjusting the test voltage level for the various ranges and selecting the impedance level of the various ranges.

The test signal, as presented at the front panel, electrically appears as though it is being originated by a voltage generator with a series output impedance. The open circuit voltage and generator impedance are both different for all three ranges.

Figure 3 shows the electrical equivalent of the generator section and how the voltage across the terminals affects the horizontal and vertical deflection plates of the CRT. Shown is the symbolic representation of a voltage generator (GEN) with a series internal impedance (Z_{gen}) and a current sensing point (I). Across these network elements are two test points A and COM.

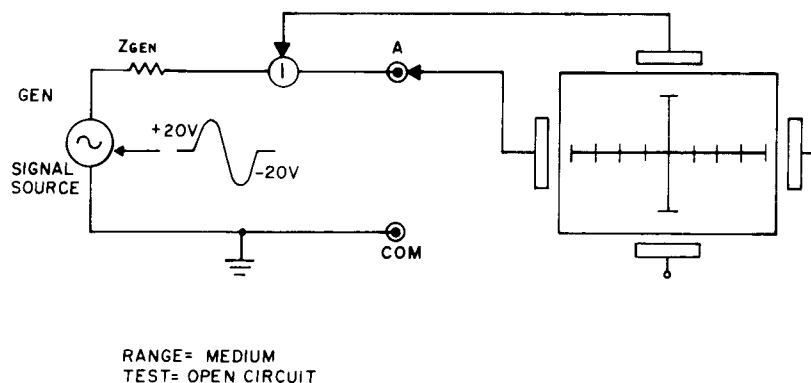

FIG 3

An open circuit (such as that shown in **Figure 3**) has zero current flowing through the test leads and has maximum voltage across the test leads. In the HIGH and MEDIUM ranges this is represented by a straight horizontal trace from the maximum left to the maximum right of the CRT. In the LOW range, an open circuit condition is shown as a diagonal trace from the upper right to the lower left corner of the CRT. **Figure 4a** shows scope traces in HIGH, MEDIUM and LOW ranges.

When the test leads are shorted, maximum current flows in the leads and there is zero voltage across the lead. This is indicated by a vertical trace from the top to the bottom of the CRT on all ranges (see **Figure 4b**).

OSCILLATOR PCB ASSEMBLY:

(Refer to **Figure 16** and **Figure 17**)

Unless otherwise specified:

All fixed resistors are ¼W, 5%, carbon film

All resistor values are in ohms

REF. DES.	DESCRIPTION		HUNTRON® PART NO.
A2	Oscillator PCB Assembly		07-1018
PCB2	Oscillator PCB		07-7730
C1	Cap, Mylar	0.1uF, 250V, 5%	03-3026
C2	Cap, Mylar	0.1uF, 250V, 5%	03-3026
C3	Cap, Mylar	0.1uF, 250V, 5%	03-3026
C4	Cap, Mylar	0.15uF, 250V, 5%	03-3048
C5	Cap, Mylar	0.1uF, 250V, 5%	03-3026
C6	Cap, Mylar	0.022uF, 250V, 5%	03-3049
D1	Diode, Signal	IN914	04-4007
D2	Diode, Signal	IN914	04-4007
D3	Diode, Signal	IN914	04-4007
D4	Diode, Signal	IN914	04-4007
D5	Diode, Signal	IN914	04-4007
D6	Diode, Signal	IN914	04-4007
IC1	IC, 2.5 Volt Ref.	LM336BZ-2.5	05-5011
IC2	IC, 2.5 Volt Ref.	LM336BZ-2.5	05-5011
IC3	IC, Dual Op Amp	LM1458N	05-5012
PL1	Header, 5 Pin		07-7152
Q1	Transistor, PNP, 300V	MPSA92	05-5015
Q2	Transistor, PNP, Power	TIP 30	05-5008
Q3	Transistor, NPN, 300V	MPSA42	05-5003
Q4	Transistor, NPN, Power	TIP 29	05-5007
R1	Pot, Trimmer	10k	02-2084
R2	Resistor	13k	02-2160
R3	Resistor	68k	02-2103
R4	Resistor	68k	02-2103
R5	Resistor	120	02-2146
R6	Resistor	2.2k	02-2079
R7	Resistor	680	02-2100
R8	Resistor	120	02-2146
R9	Resistor	470	02-2098
R10	Resistor	68	02-2148
R11	Resistor	470	02-2098
R12	Resistor	68	02-2148
R13	Resistor	120	02-2146
R14	Resistor	120	02-2146
R15	Pot, Trimmer	500	02-2147
R16	Resistor	2.2k	02-2079
R17	Resistor	680	02-2100
R18	Resistor	10k	02-2137
R19	Resistor	4.7k	02-2145

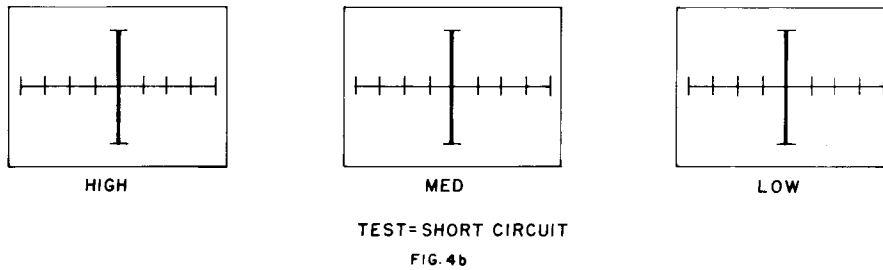
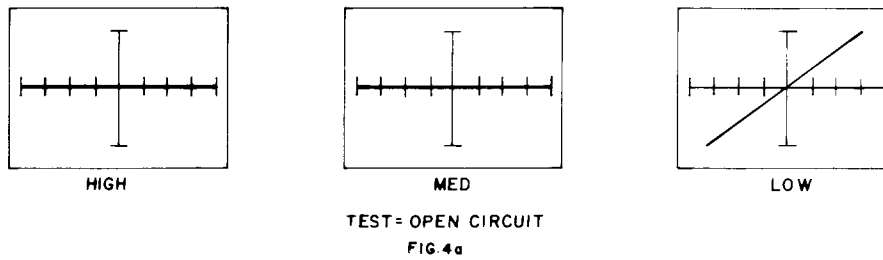

A pure resistance across the test leads would create both current flow in and voltage drop across the resistance which would appear on the CRT as a deflected straight trace. The HIGH and MEDIUM ranges would have the trace deflected clockwise around the center of the CRT from the horizontal position (open circuit), while the LOW range would have the trace deflected clockwise from the open circuit diagonal position. On all ranges the length of the trace is reduced because of the internal voltage drop across Z_{gen} caused by the resistor load and the trace is rotated toward a more vertical position because of the increased current through the load. The amount of trace reduction and rotation depends upon the test resistance value and the range chosen for the test.

Since a pure resistance is a linear electrical element, the resulting trace will always be a straight line. Non-linear electrical elements that are not reactive do not give a straight line over the entire trace length. **Figure 5** shows the trace with a 33 kohm resistor across the test leads in the MEDIUM range. The resistor causes the horizontal deflection voltage to be reduced because of the current flow through the resistor. The vertical deflection voltage is proportional to the current flow and the resulting pattern is a clockwise rotated trace that is shorter than the open circuit trace. The peak current through the resistor is 320 microamps. The actual short circuit peak current is 730 microamps. The generator impedance in the HIGH range is 75 kohms, in the MEDIUM range is 27 kohms, and in the LOW range is 56 ohms.

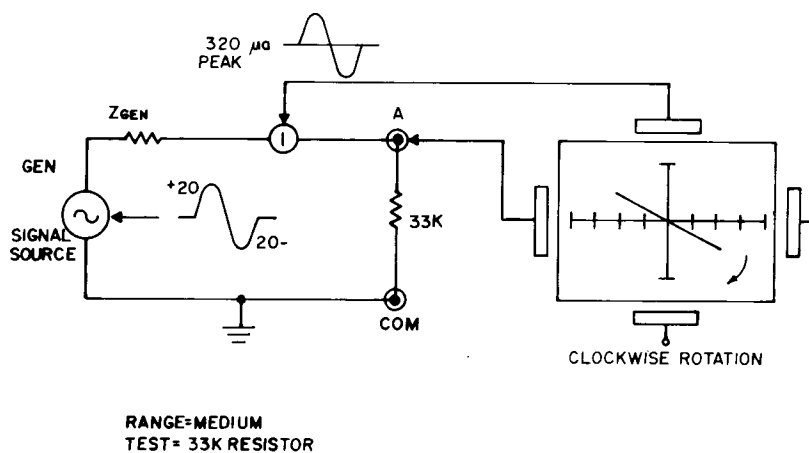

FIG. 5

REF. DES.	DESCRIPTION		HUNTRON® PART NO.
R8	Res, Metal Film	86.6k, 1%	02-2136
R9	Res, Metal Film	42.2k, 1%	02-2122
R10	Res, Metal Film	681k, 1%	02-2123
R11	Res, Metal Film	1.96M, 1%	02-2150
R12	Thermistor	5k	02-2110
R13	Resistor	68k	02-2103
R14	Resistor	22k	02-2157
R15	Pot, Trimmer	50k	02-2085
R16	Pot, Trimmer	25k	02-2155
R17	Resistor	20K	02-2082
R18	Resistor	10k	02-2137
R19	Pot, Trimmer	500k	02-2058
R20	Res, Metal Film	196k, 1%	02-2153
R21	Resistor	590k, 1%	02-2154
R22	Pot, Trimmer	10k	02-2084
R23	Resistor	180k	02-2124
R24	Resistor	1k	02-2125
R25	Resistor	1.6k	02-2135
R26	Resistor	180k	02-2124
R27	Resistor	1k	02-2125
R28	Resistor	1.6k	02-2135
R29	Resistor	180k	02-2124
R30	Resistor	1k	02-2125
R31	Resistor	180k	02-2124
R32	Resistor	1k	02-2125
R33	Resistor	16k	02-2134
R34	Resistor	3k	02-2126
R35	Pot, Trimmer, Cermet	1M	02-2070
R36	Res, High Voltage	5M, ½ W	02-2088
R37	Pot, Trimmer, Cermet	1M	02-2070
R38	Pot, Control	500k	02-2095
R39	Resistor	68k	02-2103
R40	Resistor	4.7M	02-2127
R41	Resistor	1M	02-2130
R42	Resistor	10M, ½ W	02-2102
R43	Resistor	10M, ½ W	02-2102
R44	Resistor	10M, ½ W	02-2102
R45	Resistor	10M, ½ W	02-2102
R46	Resistor	5M, ½ W	02-2088
R47	Pot, Trimmer	50k	02-2085
R48	Resistor	27K	02-2133
R49	Resistor	1k	02-2125
R50	Resistor	2.2M	02-2131
R51	Resistor	2.2k	02-2079
R52	Resistor	10k	02-2137
R53	Resistor	200k	02-2140
R54	Resistor	2.0M	02-2129
SO1	Socket, 5 Pin		07-7149
SW1-SW4	Switch Assembly		07-7067
TB1	Terminal Block		07-7065
TR1	Transformer, Signal		06-6030
Z1	ZNR 130V		02-2038
	ZNR 250V		02-2061

A non-linear component such as a silicon diode would allow a large current to flow during the half cycle when it is forward biased and very little current to flow during the reverse biased half cycle. The voltage drop across the forward biased junction would be small (i.e. 0.7 V.), and this would appear as a near short causing a vertical trace to appear during that portion of the cycle. The reverse biased condition would cause very little current to flow and would look like an open circuit trace on the CRT.

Figure 6a shows a silicon diode junction being observed with the TRACKER® in the LOW range, while **Figure 6b** shows traces in HIGH and MEDIUM ranges.

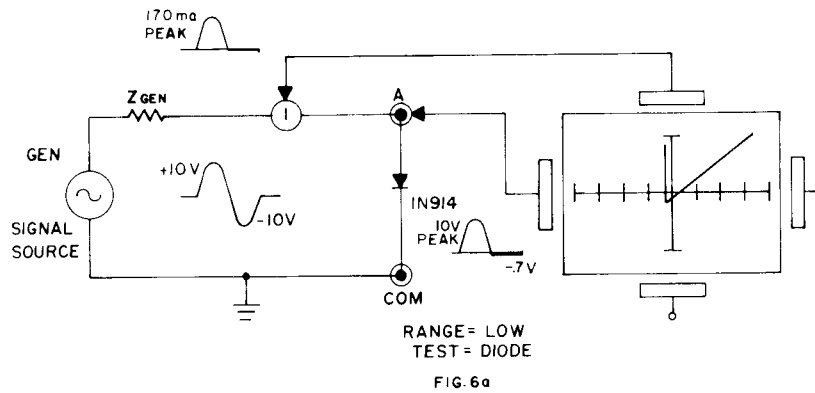

FIG. 6a

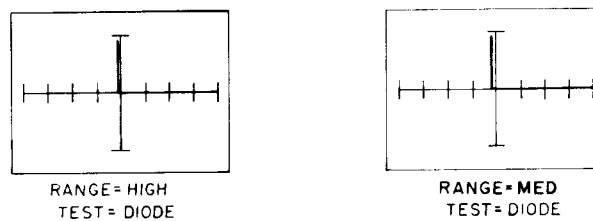
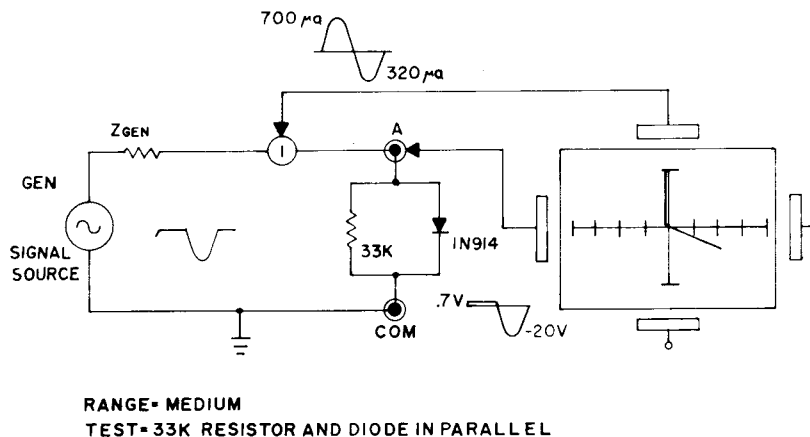

FIG 6b

Figure 7 shows a 33 kohm resistor being shunted by a silicon diode. During the first half of the test signal the junction is forward biased and appears as a near short circuit to the test signal resulting in the vertical trace shown in the second quadrant of **Figure 7**. Then the test signal reverses polarity during the second half cycle and the diode becomes reverse biased. The reverse biased resistance of the diode is much greater than the 33 kohm resistance, so essentially all of the current flows through the 33 kohm resistor creating the CRT pattern shown in the fourth quadrant of **Figure 7**.



RANGE = MEDIUM
TEST = 33K RESISTOR AND DIODE IN PARALLEL

FIG. 7

REF. DES.	DESCRIPTION		HUNTRON® PART NO.
D1	Diode, Signal	IN914	04-4007
D2	Diode, Rectifier	HV15F	04-4010
D3	Diode, Rectifier	HV15F	04-4010
D4	Diode, Rectifier	IN4005	04-4012
D5	Diode, Rectifier	IN4005	04-4012
D6	Diode, Rectifier	IN4005	04-4012
D7	Diode, Rectifier	IN4005	04-4012
D8	Diode, Rectifier	IN4001	04-4006
D9	Diode, Rectifier	IN4001	04-4006
D10	Diode, Rectifier	IN4001	04-4006
D11	Diode, Rectifier	IN4001	04-4006
F1	Fuse, 250V ¼ Amp AGX		02-2132
F2	Fuse, 250V ¼ Amp AGX		02-2132
F3	Fuse, 250V ¼ Amp AGX		02-2132
IC1	IC, Dual Op Amp	LM1458N	05-5012
IC2	IC, Op Amp	LM741CN	05-5009
IC3	IC, Pos. Reg., +6V	MC7806CT	05-5004
IC4	IC, Neg. Reg., -6V	MC7906CT	05-5005
J1	Jack		01-1070
L1	Line Cord, 110V/120V Line Cord, 220V/240V		01-1027 01-1049
MP1	Heat Sink		07-7151
MP2	Regulator Insulator		07-7084
MP3	Bushing Nylon Shoulder		07-7119
MP4 (2)	Screw, 4/40, 3/8 Inch		07-7086
MP5 (2)	Nut Hex, 4/40		07-7087
MP6 (2)	Washer, Lock, Star, #4		07-7089
MP7	Test Pin		07-7153
MP8 (6)	Fuse Clip		02-2044
MP9	Threaded Standoff 6-32 1"		07-7156
MP10	Screw, 6-32 3/8"		07-7172
MP11	Washer, Lock Star #6		07-7171
PL1	Header, 6 Pin		07-7224
PL2	Header, Polarized, 12 Pin		07-7158
PL3	Header, Polarized, 12 Pin		07-7158
Q1	Transistor, NPN 300V	MPSA42	05-5003
Q2	Transistor, NPN 300V	MPSA42	05-5003
Q3	Transistor, NPN	PN2222	05-5013
Q4	Transistor, NPN 300V	MPSA42	05-5003
Q5	Transistor, NPN 300V	MPSA42	05-5003
Q6	Transistor, NPN	PN2222	05-5013
Q7	Transistor, NPN 400V	TIP 50	05-5016
R1	Resistor	6.8, 1W	02-2086
R2	Pot, Trimmer	5k	02-2090
R3	Pot, Trimmer	5k	02-2090
R4	Pot, Trimmer	5k	02-2090
R5	Resistor	220, ½ W	02-2003
R6	Resistor	10, ½ W	02-2077
R7	Pot, Trimmer	100k	02-2091

Figure 8 shows a silicon diode shunted by a 10 ohm resistor with the LOW range selected. During the first half of the cycle the junction is forward biased and in parallel with the 10 ohm resistor. The combined currents of the two devices in parallel is very high and causes a near vertical trace on the CRT.

A vertical line represents a short circuit (zero voltage drop) condition, and, since the junction does not have appreciable conduction until a forward voltage of approximately 0.7 Volts is generated, the vertical trace is displaced to the left by this amount. This is shown as the straight vertical portion of the trace in the second quadrant of **Figure 8**.

In the reverse direction the diode is essentially out of the circuit and all of the current flows through the resistor. This causes the trace in the fourth quadrant and part of the second quadrant of **Figure 8**.

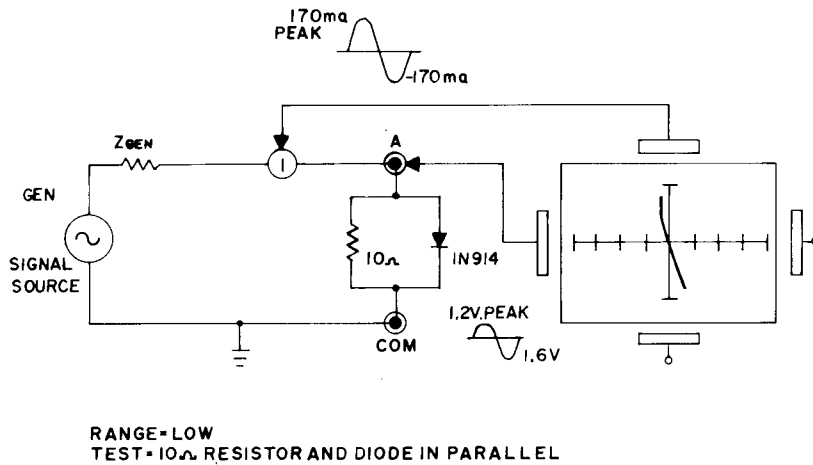

FIG. 8

TESTING REACTIVE COMPONENTS

Figure 9 shows the trace from a 1μF capacitor in the MEDIUM range. The reactance of the capacitor is approximately 2 kohm at 80 Hz. This is appreciably less than the generator impedance of 27 kohm and causes a relatively high current flow with a fairly low voltage drop. Also, since the generator is resistive and the test component is reactive, the current (vertical) is 90 degrees out of phase with the voltage (horizontal). The above signal amplitudes when combined with this phase shift result in the display of a narrow vertical ellipse on the CRT.

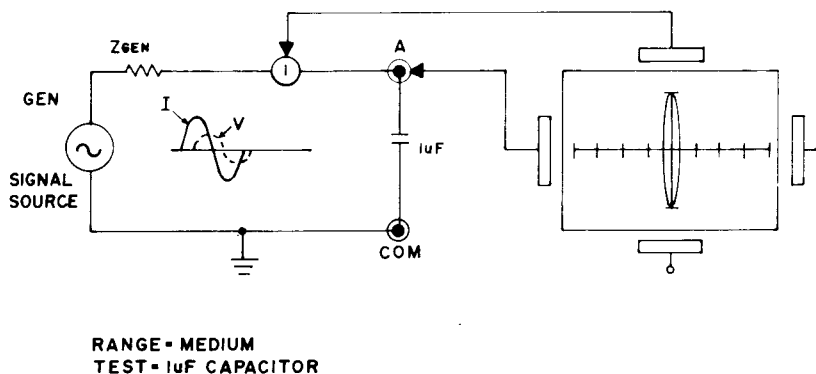

FIG. 9

LIST OF REPLACEMENT PARTS

This section contains a parts breakdown of the HTR 1005B-1S, B-1ES, B-1JS. Each component is designated alphanumerically, and can be referenced to assembly drawings or schematics.

HOW TO ORDER PARTS:

Components may be ordered directly from manufacturer by using manufacturer's part number, or from **HUNTRON® INSTRUMENTS, INC.**, or its authorized distributor, by **HUNTRON® PART NUMBER**.

For prompt and efficient handling of your order, please supply:

1. Model and Serial Number
2. Reference Designation
3. Part Description
4. **HUNTRON®** Part Number
5. Quantity

MAIN PCB ASSEMBLY:

(Refer to **Figure 14** and **Figure 15**)

Unless otherwise specified:

All fixed resistors are ¼W, 5%, carbon film
All resistor values are in ohms

REF. DES.	DESCRIPTION		HUNTRON® PART NO.
A1	Main PCB Assembly	117V	07-1031
A1	Main PCB Assembly	220V/240V	07-1032
A1	Main PCB Assembly	100V	07-1033
PCB1	Main PCB		07-7706
C1	Cap, Ceramic	0.001uF, 100V	03-3030
C2	Cap, Ceramic	0.001uF, 100V	03-3030
C3	Cap, Electrolytic	1uF, 450V	03-3040
C4	Cap, Ceramic	0.001uF, 1400V	03-3023
C5	Cap, Ceramic	0.001uF, 1400V	03-3023
C6	Cap, Ceramic	0.02uF, 1000V	03-3004
C7	Cap, Electrolytic	1uF, 450V	03-3040
C8	Cap, Electrolytic	1uF, 450V	03-3040
C9	Cap, Electrolytic	1uF, 450V	03-3040
C10	Cap, Electrolytic	1uF, 450V	03-3040
C11	Cap, Electrolytic	1uF, 100V	03-3006
C12	Cap, Electrolytic	22uF, 250V	03-3043
C13	Cap, Electrolytic	1000uF, 16V	03-3024
C14	Cap, Electrolytic	1000uF, 16V	03-3024
C15	Cap, Tantalum	10uF, 25V	03-3011
C16	Cap, Tantalum	10uF, 25V	03-3011
C17	Cap, Electrolytic	2200uF, 6.3V	03-3045
C18	Cap, Electrolytic	2200uF, 6.3V	03-3045
C19	Cap, Ceramic	0.01uF, 2000V	03-3042

When the vertical and horizontal signal amplitudes are equal and the current-voltage phase shift is 90 degrees, the result is a circular trace. In MEDIUM range this occurs when a 0.13uF capacitor is placed across the input terminals as shown in **Figure 10**.

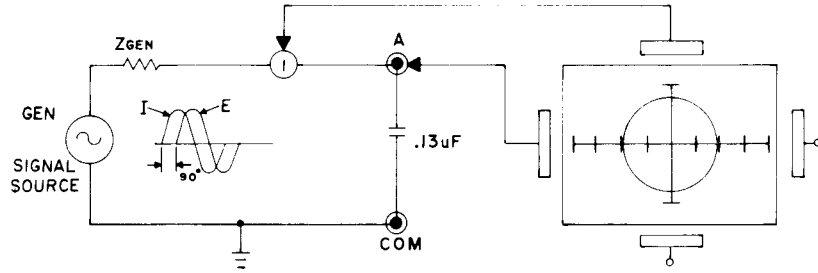

RANGE = MEDIUM
TEST = .13uF CAPACITOR

FIG 10

Figure 11 shows the CRT pattern that results from shunting a 0.13uF capacitor with a 20 kohm resistor in the MEDIUM range. The resistor across the capacitor alters the current-voltage phase angle in such a way that the circle narrows to an ellipse and there is a counterclockwise rotation of the ellipse from the vertical axis.

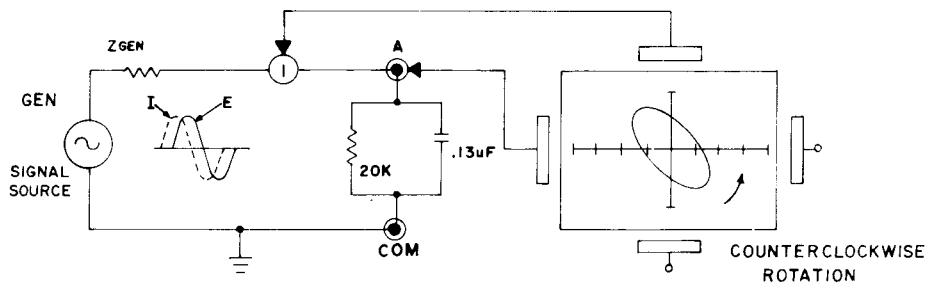

RANGE = MEDIUM
TEST = .13uF CAPACITOR AND 20K RESISTOR IN PARALLEL

FIG 11

CRT SECTION

SYMPTOM: Trace out of focus.

CONDITIONS: Test terminals open or shorted. All ranges.

PROBABLE CAUSES: (a) R37, R38, R39, R40, R41 open or shorted.
(b) C3 shorted.
(c) -1350 Volt very low.
(d) + 180 Volt very low.
(e) CRT socket wires open or shorted.

SYMPTOM: Intensity control has no effect.

CONDITIONS: Test terminals open or shorted. All ranges.

PROBABLE CAUSES: (a) C3 shorted.
(b) Intensity control pot R40 open.
(c) -1350 Volt very low.

SYMPTOM: No trace.

CONDITIONS: Test terminals open or shorted. All ranges.

PROBABLE CAUSES: (a) + 180 Volt plate deflection missing.
(b) -1350 acceleration voltage missing.
(c) Filament voltage missing.

SYMPTOM: Distorted Ellipse.

CONDITIONS: 0.1 uF across test terminal on HIGH and MED range.
100 uF across test terminal on LOW range.

PROBABLE CAUSES: (a) Line voltage low.
(b) Distorted Oscillator output.
(c) High voltage adjust trim pot R51 setting change.

OSCILLATOR SECTION

Refer to **Figure 16** and **Figure 17**.

SYMPTOM: No oscillator output.

CONDITIONS: Test terminals open or shorted. All ranges.

PROBABLE CAUSES: (a) ± 6 Volt missing.
(b) Transistor Q1, Q2, Q3, Q4 defective.
(c) IC3 defective.

CIRCUIT DESCRIPTION

SIGNAL SECTION:

Figure 12 is a basic circuit representation of the signal section of the **TRACKER®** . The circuit is shown with a test diode in place.

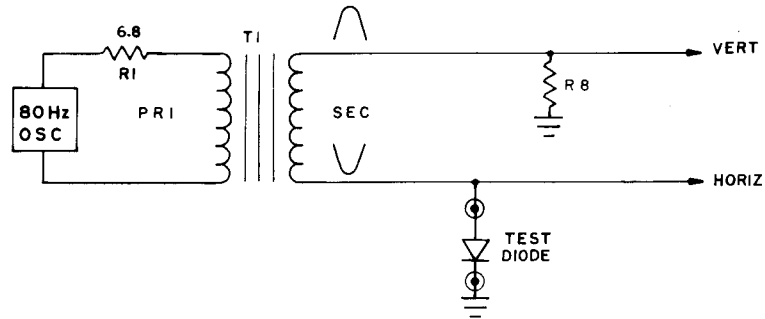

FIG.12

During the half cycle portion when the horizontal side of the secondary is negative, the test diode is reverse biased so that very little current flows through the transformer secondary and resistor R8. The vertical end of the secondary is very close to ground potential because of R8, and a very small voltage appears on the vertical lead.

Since the impedance across the horizontal side of the secondary is very high relative to that appearing on the vertical side, most of the secondary voltage will appear on the horizontal side.

During the next half cycle the horizontal side will go positive and the test diode will clamp at approximately .7 Volt. Also current will flow through R8 creating a large voltage at the vertical side of the secondary. The voltage that appears across R8 is a direct representation of the current that flows through the test diode.

SYMPTOM: Trace horizontally off screen. Trace off center of screen.

CONDITIONS: Test terminals open or shorted. All ranges.

PROBABLE CAUSES: (a) Resistor R26, R33 changed value.
(b) Q4, Q5, Q6, IC1B defective.
(c) Resistor R43, R44 changed value.
(d) Capacitors C4, C5 shorted.

SYMPTOM: Trace vertically off screen. Trace vertically off center of screen.

CONDITIONS: Test terminals open or shorted. All ranges.

PROBABLE CAUSES: (a) Resistor R23, C29 changed value.
(b) Q1, Q2, Q3, IC1A defective.
(c) Resistor R43, R44 changed value.
(d) Capacitors C4, C5 shorted.

SYMPTOM: Horizontal tilt trim pot does not change horizontal tilt.

CONDITIONS: Open test terminals on HIGH and MED ranges.

PROBABLE CAUSES: (a) R12, R13, R14, R16, R17, R18 open.
(b) Range select switch defective.
(c) PCB etching open or shorted to ground.

SYMPTOM: Vertical tilt trim pot does not change vertical tilt.

CONDITIONS: Test terminals shorted.
The range that this condition occurs.

PROBABLE CAUSES: (a) Vertical tilt trim pot for the defective range open.
(b) Broken wire on signal transformer.

SYMPTOM: Split trace.

CONDITIONS: Open test terminals. All ranges.

PROBABLE CAUSES: Signal transformer defective.

SYMPTOM: Excessive motion at end of trace.

CONDITIONS: Test terminals open or shorted. All ranges.

PROBABLE CAUSES: (a) Rectifier D9, D10, D11, D12 defective.
(b) Filter capacitor C15, C16, C17, C18, C19, C20 defective.
(c) ± 6 Volt regulators defective.
(d) Power line noise.
(e) Power transformer defective.
(f) **TRACKER**[®] in close proximity to high level 50 or 60 Hz transformer.
(g) Line voltage drop to such a low level that it is out of high voltage regulation range.

Figure 13 is a more detailed circuit description with the HIGH range selected. R4 provides for a phase angle correction when the test points are shorted and compensates for CRT distortion.

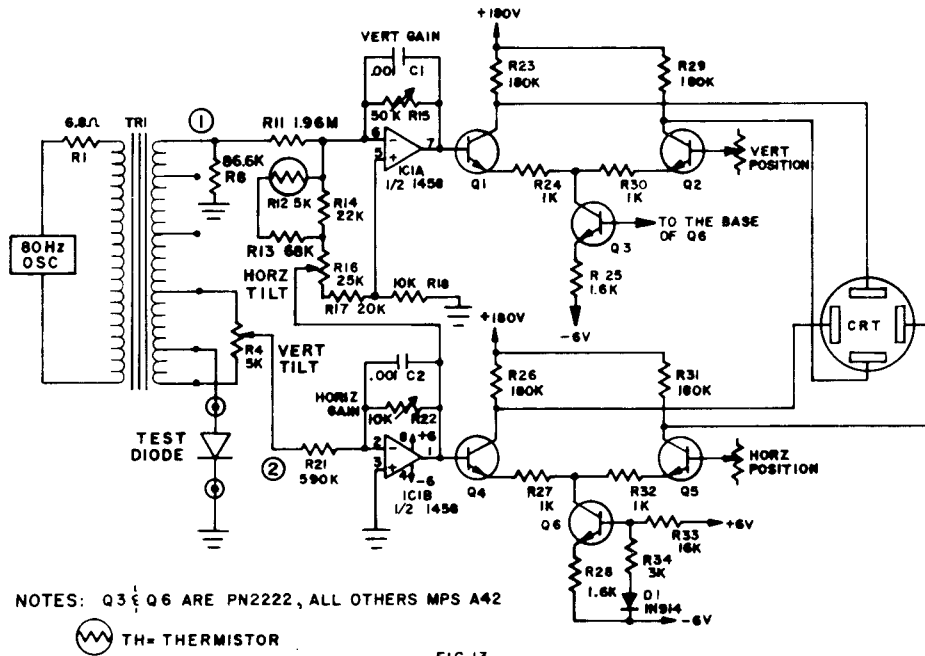

FIG. 13

R16 is the horizontal phase correction and compensates for the impedance of R21 going into the horizontal amplifier as well as CRT distortion. Referring back to **Figure 12**, it was shown that maximum voltage appears at the horizontal end of the secondary only when there is infinite impedance presented by R21 and IC1. R16 corrects for this difference.

Referring to **Figure 13**, R15 and R22 are the vertical and horizontal gain adjustments respectively. Transistors Q1, Q2, Q3, and associated components form the vertical amplifier, while Q4, Q5, Q6, and associated components form the horizontal amplifier. These amplifiers are temperature compensated to avoid drifting.

A positive or negative going signal at point (1) will be amplified, phase corrected, and placed on the vertical deflection plate of the CRT. A positive or negative signal at point (2) will be amplified, phase corrected, and placed on the horizontal deflection plate.

Vertical and horizontal positions are controlled by a variable DC voltage on the bases of transistors Q2 and Q5 respectively.

Signal transformer TR1 is designed to close tolerances so as to provide the proper secondary voltage and impedance levels.

SYMPTOM: DEAD UNIT: Front panel power indicator light on. No trace.
CONDITIONS: Test terminals open or shorted. All ranges.
PROBABLE CAUSES: (a) No high voltage -1350 volt.
(b) Diode D3, D4, C9, C10, C11, C12 defective.
(c) Transformer secondary winding N7 open.

SYMPTOM: Power indicator light on. Only a "dot" appears on CRT.
CONDITIONS: Test terminals open or shorted. All ranges.
PROBABLE CAUSES: (a) No plate deflection voltage.
(b) D5, D6, D7, D8 defective.
(c) C14 shorted.
(d) Transformer secondary winding N6 open.

SYMPTOM: Acceleration voltage reads -1650 Volt, and adjusting trim pot R51 does not change voltage.
CONDITIONS: Test terminals open or shorted. All ranges.
PROBABLE CAUSES: (a) Bad trim pot R51.
(b) Defective IC2.
(c) Defective transistor Q7.

SIGNAL SECTION

SYMPTOM: Dot in center of screen. No horizontal and vertical sweep.
CONDITIONS: Test terminals open or shorted. All ranges.
PROBABLE CAUSES: (a) No oscillator output (See oscillator section).
(b) Signal transformer TR1 defective.
(c) ± 6 Volt at Oscillator Module missing.
(d) ± 6 Volt plate deflection voltage missing.

SYMPTOM: Dot in center of screen. No horizontal sweep.
CONDITIONS: Test terminal open. HIGH and MED ranges.
PROBABLE CAUSES: (a) IC1B defective.
(b) R22 shorted.

OSCILLATOR:

Refer to **Figure 16** for schematic. The oscillator is a 2½ inch by 4 inch PCB module which plugs into a socket on the main PCB. It provides an 80 Hz sine wave test signal which has an output amplitude that is factory adjusted to 10 volts peak-to-peak. For adjustment details, see the section on Internal Set-Up and Adjustments.

POWER SUPPLY

Refer to **Figure 14** for schematic, and **Figure 15** for component layout.

The power supply section provides various operating voltages:

- (1) -1350 Volt Regulated High Voltage.
D3, D4, C9, C10, C11, C12, R46, R47, R48, and R49 form a voltage doubler; Q7 and IC2 provide linear voltage regulation. For adjustment details see Internal Set-Up and Adjustments Section.
- (2) + 180 Volt Unregulated Deflection Voltage.
Diodes D5, D6, D7, and D8 form a full wave bridge rectifier, and C14 is the filter capacitor. Bleeder resistor R57 discharges voltage in C14 to a safe level within 60 seconds after power is turned off.
- (3) + 6/-6 Volt Regulated Voltage.
Diode D9, D10, D11, and D12 form a bridge rectifier; IC3 and IC4 provide regulation for + 6 Volt and -6 Volt respectively.
- (4) 6.3 Volt Filament Voltage.
The power transformer supplies this voltage to the filament of the CRT.

Switch SR5 sets up power transformer TR2 for 220 Volt or 240 Volt environments in the European Economic Community.

CATHODE RAY TUBE CIRCUIT:

The CRT is a 7 cm diagonal, green phosphor, electrostatic type.

The high voltage is adjusted to -1350 Volts for normal operation.

INTENSITY ADJUST: R40 is the CATHODE VOLTAGE CONTROL and controls CRT intensity via a front panel knob (BRIGHT). The cathode voltage can be adjusted from -1235 Volts to -1336 Volts.

FOCUS ADJUST: R39 is the FOCUS CONTROL and has a voltage range of -1033 Volts to -1235 Volts.

ASTIGMATISM: R37 adjusts for astigmatism and has a voltage range of -22 Volts to + 180 Volts.

FRONT PANEL CONTROLS:

Refer to **Figure 18** for schematic.

R1 and R2 control the vertical and horizontal CRT trace positions respectively.

The changes in trace positions are accomplished by varying the base voltages of transistors Q2 and Q5 in the differential amplifiers.

Switch SW6 selects the display of either Input A or Input B or alternating between display A and B.

FIG. 23

WAVEFORM AT VARIOUS TEST POINTS ON MAIN PC BOARD
TIME BASE: 5MS/DIV

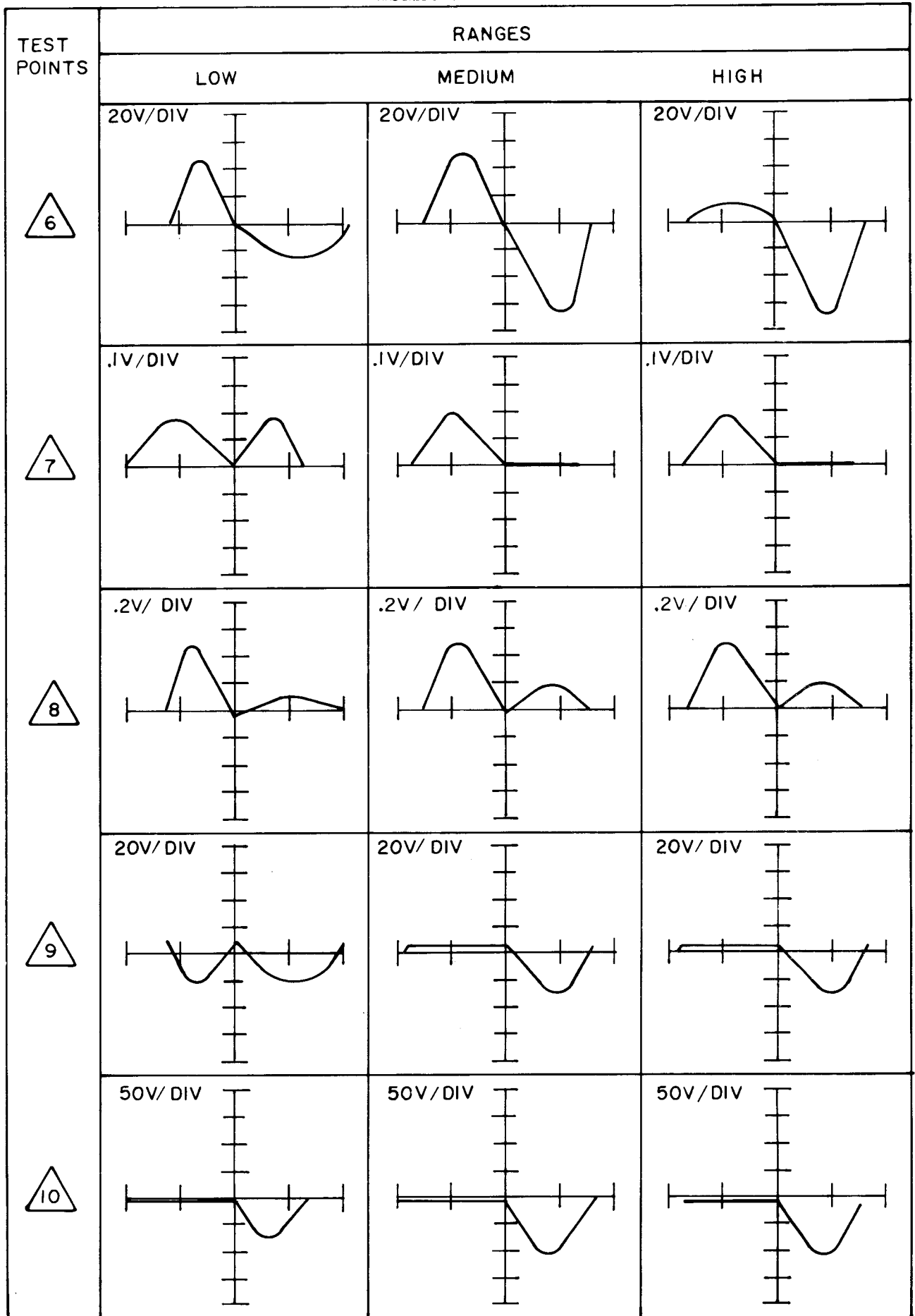

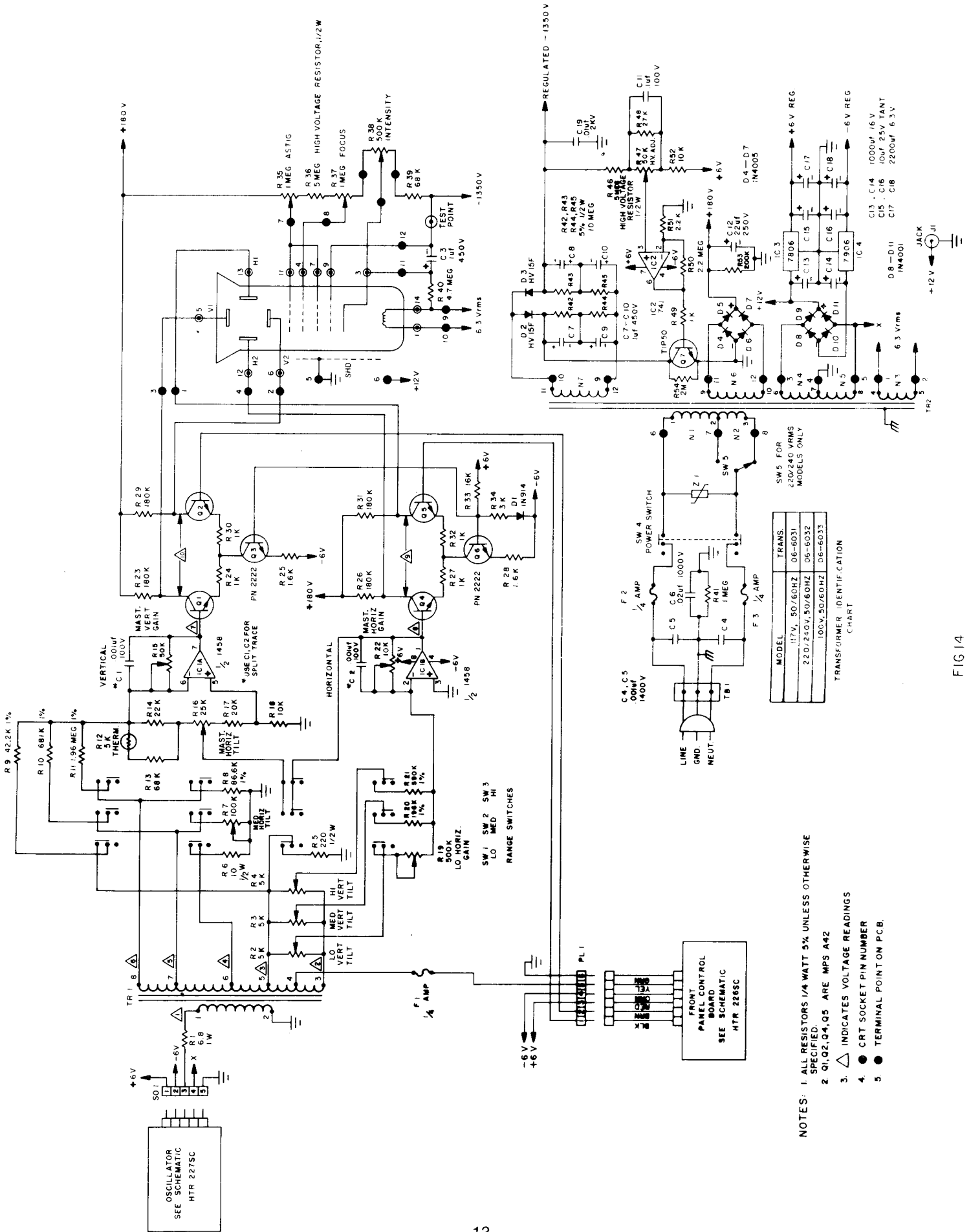

- NOTES:
1. ALL RESISTORS 1/4 WATT 5% UNLESS OTHERWISE SPECIFIED.
 2. Q1, Q2, Q4, Q5 ARE MPS A42
 3. Δ INDICATES VOLTAGE READINGS
 4. \bullet CRT SOCKET PIN NUMBER
 5. \bullet TERMINAL POINT ON PCB.

FIG 14

FIG 22

WAVEFORM AT VARIOUS TEST POINTS ON MAIN PC BOARD
TIME BASE: 5MS/DIV

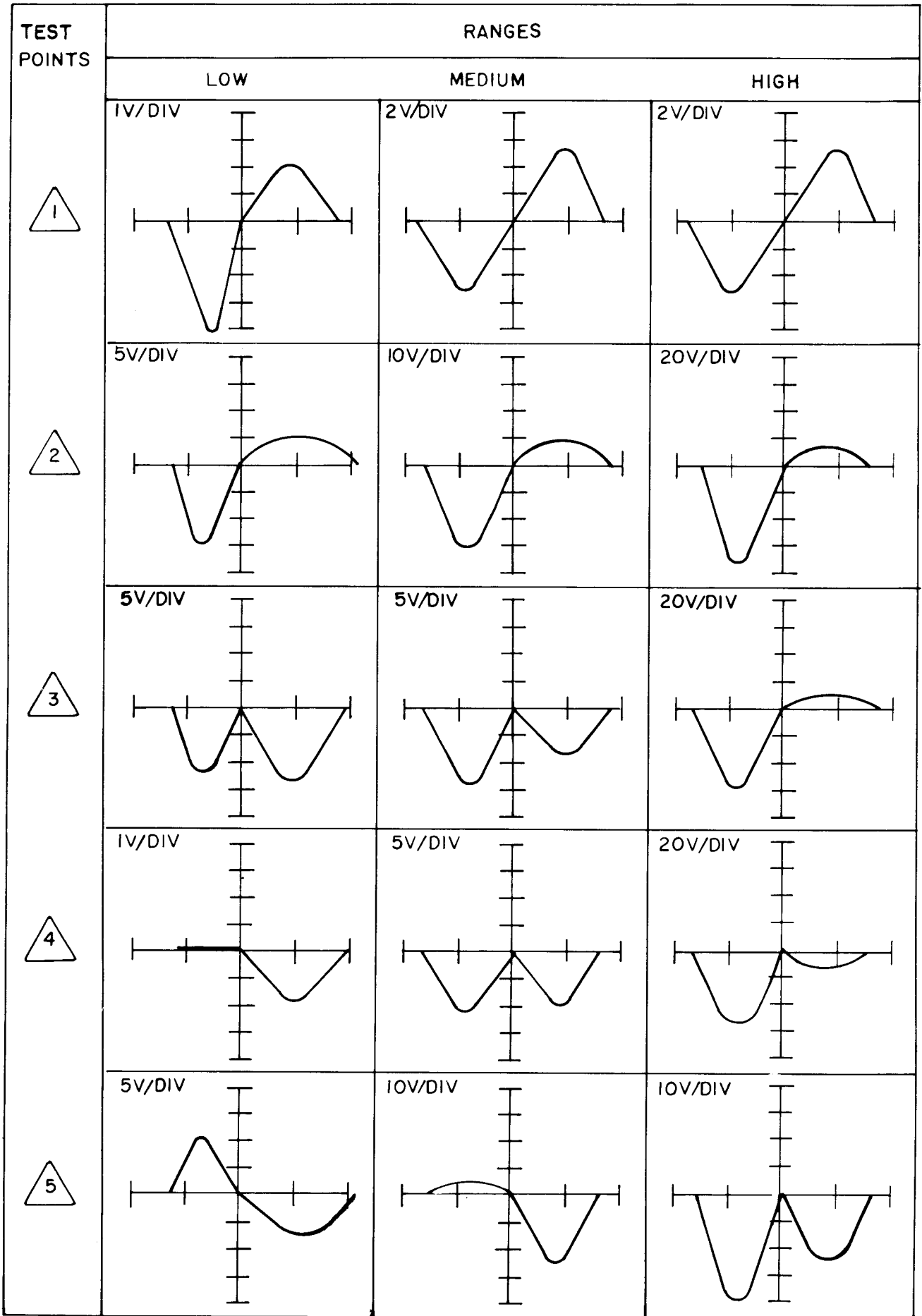

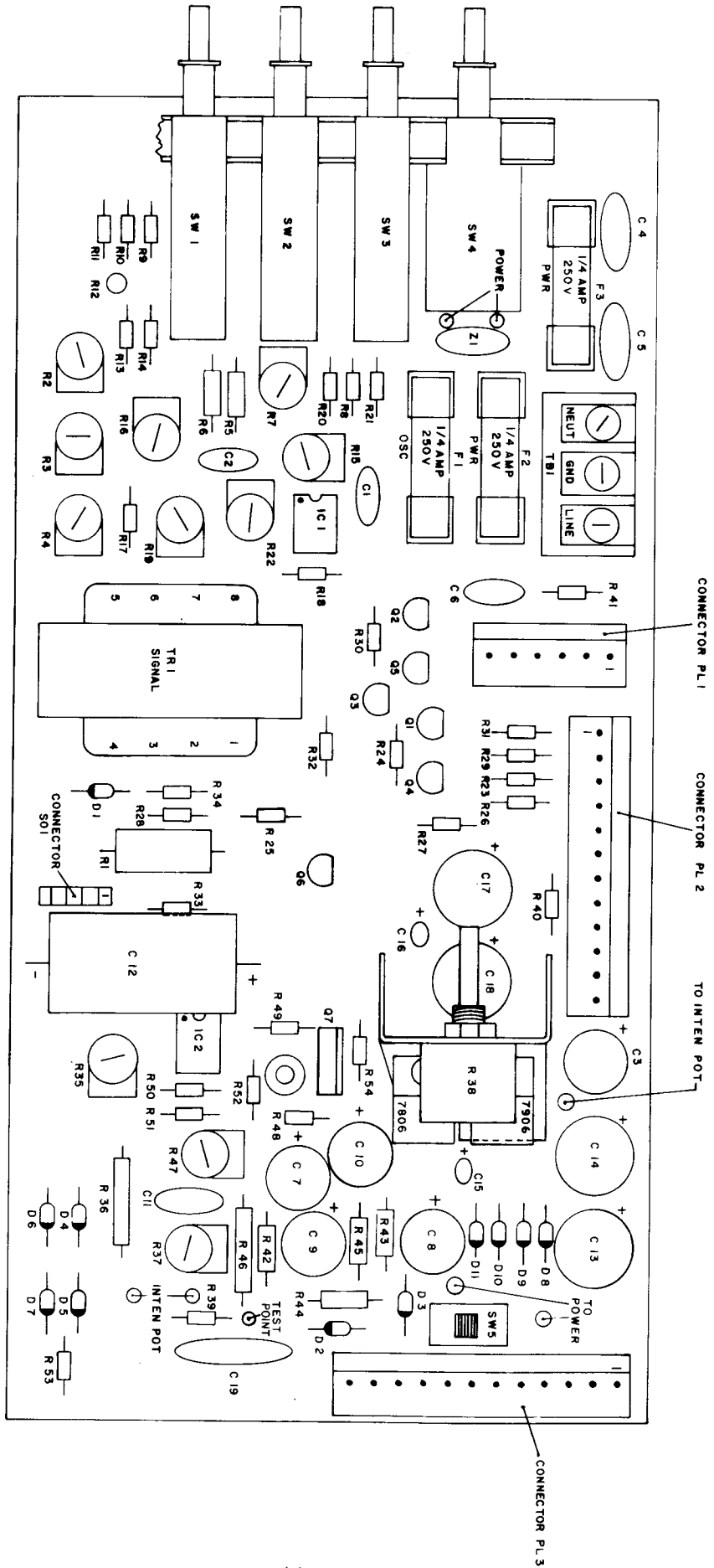

FIG. 15

TROUBLESHOOTING

GENERAL INFORMATION

A defective **TRACKER®** should always receive a very careful visual inspection prior to any expensive symptomatic troubleshooting.

Burned components, fuses or darkened areas on the printed circuit boards indicate that excessive heat has been generated, and this is usually a pretty good clue that a component in the affected area is defective.

If a visual inspection on both sides of the printed circuit board fails to indicate an obvious problem, then proceed by power on testing for the following voltages. Refer to **Figure 14** for the main **TRACKER®** schematic.

(A) Check power transformer secondary winding AC Voltages.

WINDING	N3	VOLTAGES (Vrms)	6.1
	N4		11.1
	N5		11.1
	N6		138
	N7		570

The above readings correspond to nominal AC Input.

(B) Check DC Voltages

- (1) -1350 V Acceleration Voltage
- (2) \pm 6V Signal Voltage
- (3) + 180 V Deflection Voltage

Any one of the above voltages listed in (A) and (B) should be within \pm 5% tolerance. The source of a defective voltage should be located and corrected.

If the voltages as outlined above are all correct, then proceed with a complete check of the remaining voltages as shown on the main schematic and oscillator schematic.

A final check can be made with an oscilloscope to check the waveforms as shown by the triangular numbers on the main schematic. **Figure 22** and **Figure 23** list various waveforms appearing on the main PCB.

After a circuit correction has been made, refer to the section on INTERNAL SET-UP AND ADJUSTMENTS for proper CRT trace presentation.

The following symptomatic analysis will help isolate defective circuitry and locate specific defective components.

POWER SUPPLY

SYMPTOM: DEAD UNIT: Front panel power indicator light not on when front panel power switch pushed in and power applied. No CRT trace.

CONDITIONS: Test terminals open or shorted. All ranges.

PROBABLE CAUSES:

- (a) Fuses F1 and F2 open.
- (b) Power transformer TR2 defective.
- (c) Power switch SW4 defective.
- (d) Rectifiers D9, D10, D11 or D12 defective.
- (e) Capacitors C15, C16, C17, C18, C19 or C20 shorted.
- (f) Regulators IC3, IC4 defective.

TOP VIEW

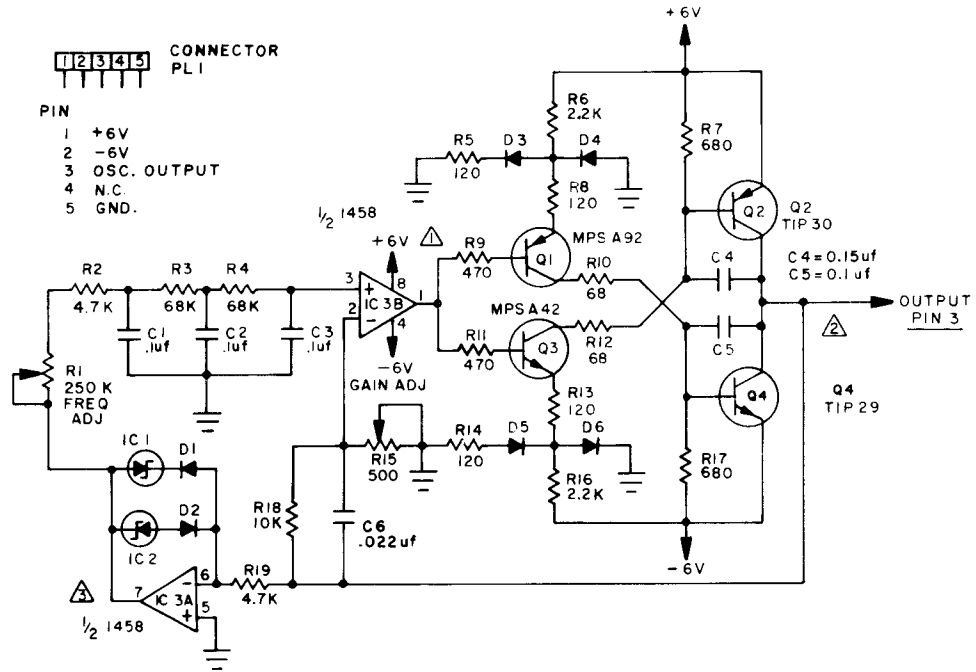
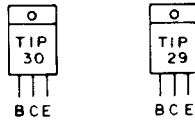

NOTES:

- ALL CAPACITORS ARE 5%
- ALL DIODES IN914
- ALL RESISTORS 1/4 WATT 5%
- ADJUST R15 UNTIL THE OUTPUT IS 10V P-P

FIG. 16

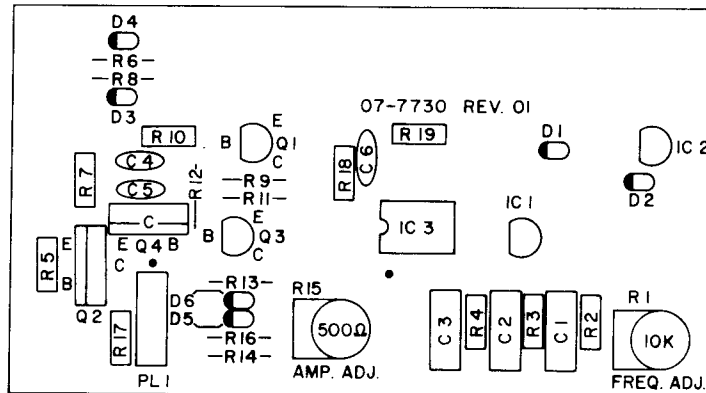
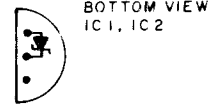

FIG. 17

- (11) Short Test Terminals.
- (12) Adjust Master Vertical Gain (R15) until vertical trace is 1-3/8 inch long.
- (13) Adjust HIGH Vertical Tilt (R4) until there is no vertical tilt.
- (14) Re-adjust Master Vertical Gain (R15) if necessary.
- (15) Remove Test Terminal short.
- (16) Adjust Master Horizontal Tilt (R16) until the horizontal trace has no tilt.
- (17) Switch to MEDIUM range position.
- (18) Short Test Terminals.
- (19) Adjust MEDIUM range Vertical Tilt (R3) until the trace has no vertical tilt.
- (20) Remove Test Terminal short.
- (21) Adjust MEDIUM Horizontal Tilt (R7) until the trace has no tilt.
- (22) Switch back and forth between HIGH and MED range, and observe the trace. It should have no horizontal tilt on either range, and the ends of the trace should be very close to the graticule, but not out of view. Both traces should be within 5% of each other in length.
- (23) Short Test Terminals, and switch back and forth between HIGH and MED ranges. Both vertical traces should be within 5% of each other in length.
- (24) Install a diode across the Test Terminals. You should see a trace as displayed in **Figure 21a**.
- (25) Final adjustments can be made on Horizontal and Vertical Gain, and Horizontal and Vertical Tilt for correct trace. The trace length difference should be less than 5%. The vertical and horizontal traces should have no tilt. Edge of trace should not go off screen.
- (26) Switch to the LOW range.
- (27) Short Test Terminals and adjust LOW range Vertical Tilt (R2).
- (28) Remove short from Test Terminals, and adjust LOW range Horizontal Gain (R19) so that trace looks like **Figure 21b**.
- (29) Insert Diode at Test Terminals.
- (30) Trace should look like **Figure 21c**.
- (31) Final focus and astigmatism adjustment can be made with diode in test terminals, and the range switch in HIGH or MEDIUM position.

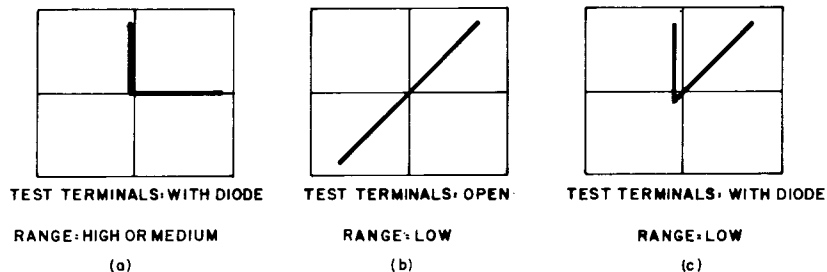
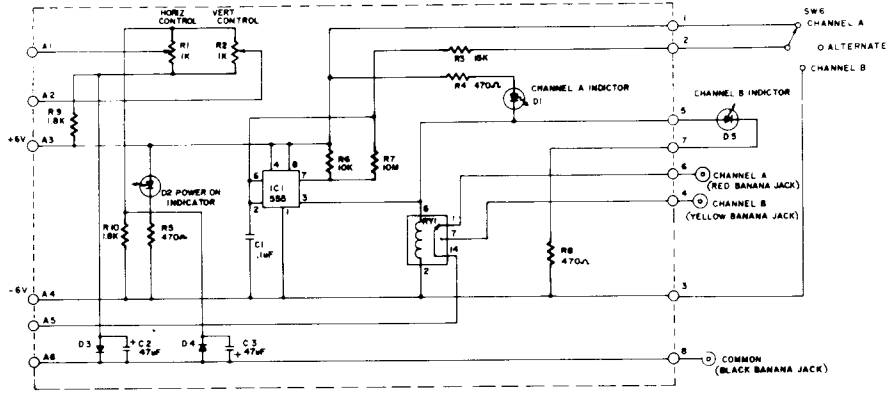

FIG. 21



NOTES: UNLESS OTHERWISE SPECIFIED
 1. ALL RESISTORS ARE 1/4 W 5%
 2. RY1 GORDOS RELAY 835-C

FIG. 18

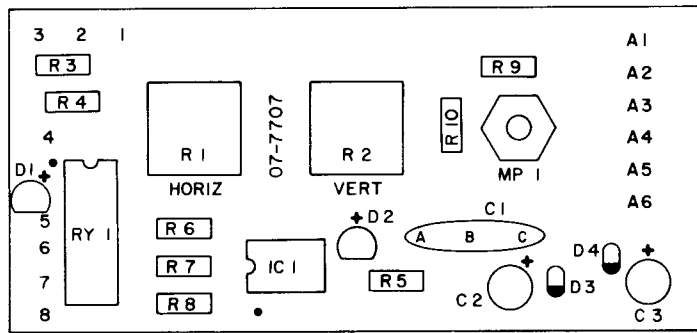

FIG. 19

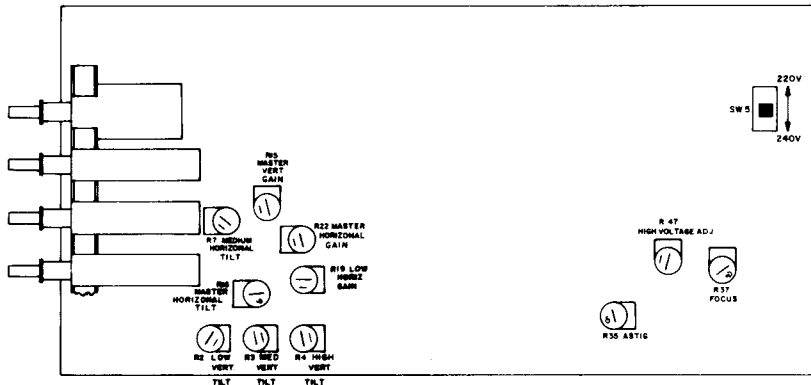

FIG. 20

INTERNAL SET-UP AND ADJUSTMENTS

Refer to **Figure 14** and **Figure 20**.

(A) POWER SUPPLY SECTION:

The High Voltage is factory adjusted to -1350 Volts, and **TRACKER®** users are advised not to re-adjust trim pot R51 unless it is absolutely necessary. The adjustment requires a digital voltmeter and a high voltage probe.

WARNING: HAZARDOUS HIGH VOLTAGE.



STEP-BY-STEP ADJUSTMENTS:

- (1) B-1ES models only set SW5. Factory set for 240V operation. Refer to Figure 20.
- (2) Connect probe common to ground point of main PCB.
- (3) Connect High Voltage Probe to Test Pin.
- (4) Turn power on.
- (5) Turn R51 until voltmeter reads -1350 Volts.

(B) OSCILLATOR SECTION:

Refer to **Figure 16** and **Figure 17**. Trackers are factory adjusted to 80 Hz.

STEP-BY-STEP ADJUSTMENTS:

- (1) Turn power on.
- (2) Connect frequency counter to point .
- (3) Turn trim pot R15 fully clockwise.
- (4) Adjust R1 until frequency counter reads 80 Hz.
- (5) Adjust R15 until Oscillator output at  is 10 Volts peak to peak.

(C) SIGNAL SECTION:

Refer to **Figure 20** for main PCB Alignment drawing.

STEP-BY-STEP ADJUSTMENTS:

- (1) Turn all trim pots (R2, R3, R4, R7, R15, R16, R19, and R22) to their fully counter-clockwise position.
- (2) Turn Horizontal and Vertical controls to the center of their range.
- (3) Turn front panel BRIGHT control fully counterclockwise.
- (4) Turn power on.
- (5) Set front panel switch to the HIGH range position.
- (6) Adjust intensity until a spot appears on the CRT.
- (7) Adjust Master Vertical Gain (R15) for vertical deflection of approximately 1/2 inch.
- (8) Adjust Focus (R39), and Astigmatism (R37) for sharpest trace. Check intensity for correct brightness.
- (9) Adjust Master Horizontal Tilt (R16) to the center of its range.
- (10) Adjust Master Horizontal Gain (R22) until trace fills out graticule.